

ESL460 Ignition/Lighting Stator Fitting Instructions

APPLICATIONS

Suzuki RM125 1993-97, RM250 1993-97 and CR500 1986

Read these instructions completely

Step 1

Take the ignition cover off. **Are The Replacement Parts Similar?** Compare the replacement part to the original. The replacement part should match, including the mounting hole locations. If not: Double check the application listing with your bike.

Step 1

Remove the flywheel using a proper puller.

Step 2

Remove the baseplate with the original stator. Disconnect the wires from the wiring loom.

Step 3

Remove existing stator coil off the baseplate and cut the BLACK/WHITE and BLACK/RED cables.

Step 4

Replace it with the new unit and feed the new leads through the holes in the baseplate.

Step 5

Screw the unit tight in position, as shown in the diagram, and make sure you use locking compound on the screws. **TIGHTEN THE SCREWS SECURELY!**

Note

Ensure the original stator has the same setup as this new ESC/ESL460, meaning 6-pole setup with only two poles wound. If it has all six poles wound, you have an older model, and you will need the ESL450!

Ignition Connection

Connect the new BLACK wire lead to the original RED/WHITE wire. Connect the new WHITE lead to the original BLACK/RED wire.

Step 6

Make sure the connections you make are good ones. Preferably you should crimp the wires together, using high quality crimps. Otherwise use solder, but be aware that solder doesn't work very well on older wiring.

Lighting Connection

Single YELLOW lighting output can be connected up straight to the lighting circuit. However it is better to use a 12V-AC regulator (ESR012) parallel in circuit. The ground tag for the lighting coil can be hooked up under the baseplate fitting screw. Take a look at our universal instructions for lighting coils for wiring details

Step 8

Ensure the wires **CANNOT TOUCH THE FLYWHEEL!**

Step 9

Refit the flywheel and tighten bolt to specified torque. Fit the ignition cover.

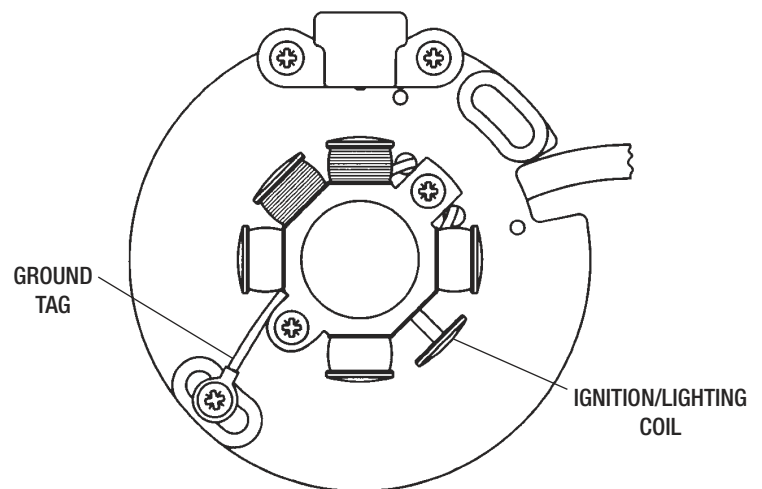

Headlight Connection

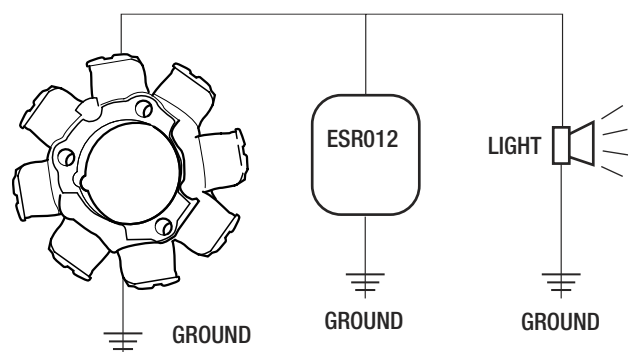

Troubleshooting

Engine will not start: Sometimes the source coil wires are reversed. Swap the connections, resolder the wires and the engine should start. If the engine still does not start, and **before calling technical support at ElectroSport**, perform a few basic tests: 1) Re-check the connections. Make sure you carefully solder the connections. Twisting wires together or taping wires will cause engine inoperability. 2) Check the engine for spark and 3) Is fresh fuel in the gas tank? If you still cannot get the engine to start, have all your testing information ready for a technician prior to calling.