

# ESG470 Stator Fitting Instructions

## APPLICATIONS

Honda CX500 A/B and other models

### Note:

The "One-Piece" generator stator replaces the original unit which is different in design and appearance.

### Please read these instructions carefully

- Step 1. Remove the engine from the frame
- Step 2. Remove the original stator coil and pick-ups from the sidecase.
- Step 3. Cut the wiring harness as close as possible to the retaining clip on the stator (approx. 80mm). But, do not cut the pick-ups. Please see the diagram on left.
- Step 4. Separate the six cables to connect to the new generator.
- Step 5. Carefully crimp and insulate with the sleeving provided on the six connections as shown below.

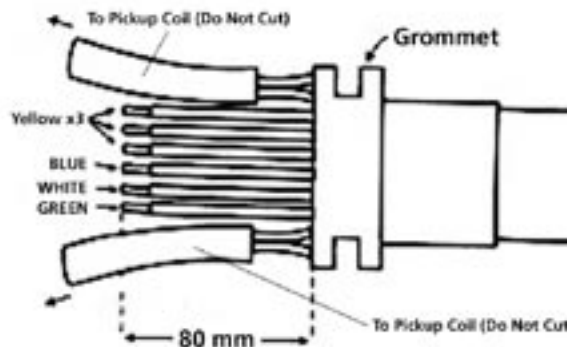

### Original Wires

GREEN

BLUE

WHITE

YELLOW (3 Wires)

### New Wires

GREEN

BLUE

WHITE

Connect to any of the 3 YELLOWS

- Step 6. Replace stator into the casing and bolt down. Position of the stator should be fitted on the 3 mounting holes as shown below.

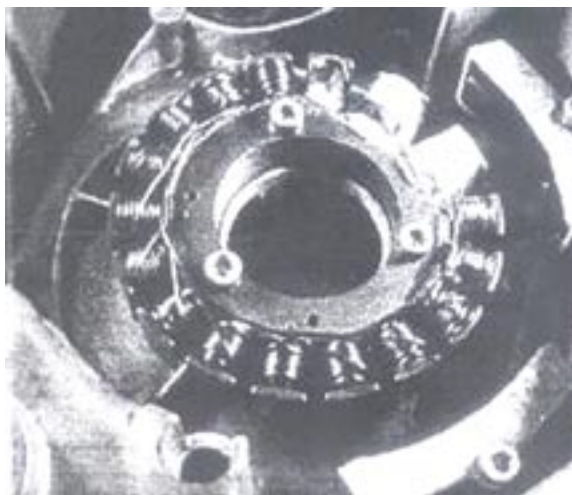

## Troubleshooting

**If the charging system is still not working:** Before calling technical support at ElectroSport, perform a few basic tests: 1) Re-check the connections, Be sure that you have used quality crimp connections. Twisting wires together or taping wires will not work. 2) Download ElectroSport's comprehensive FAULT-FINDING CHART FOR MOTORCYCLE CHARGING SYSTEMS from at: <http://www.electroSport.com> and follow all the procedures listed.