

# ESC1355 Ignition Coil Fitting Instructions

## APPLICATIONS

Yamaha YZ125 1992-1995

### Read these instructions completely

#### Step 1

Take the ignition cover off. **Are The Replacement Parts Similar?** Compare the replacement part to the original. The replacement part should match, including the mounting hole locations. If not: Double check the application listing with your bike.

#### Step 2

Take note of the wire colors of the original stator wires and disconnect them from the wiring loom.

#### Step 3

Remove the flywheel using a proper puller tool. Remove the baseplate with the original stator.

#### Step 4

Remove the screws that secure the ignition coils and take the coils off.

#### Step 5

Cut the original wires close to the original ignition coils. Take a good look at how the wires are connected to the coils. (at which side of the original coils and where each wire color goes)

#### Connections

ESC13 LARGE coil connects to the BROWN wire, connect the other side up to the RED wire. ESC55 SMALL coil connects to the BLACK wire (=ground), connect the other side up to the WHITE wire.

#### Step 6

Connect the old wires up to the new coils. Put the wires in exactly the same place as on the original. Make sure you have good connections here. Use a soldering iron and resin core solder (the type used in electrical applications).

#### Step 7

Mount the coils onto the baseplate, fit the screws using locking compound on the threads and **TIGHTEN THE SCREWS SECURELY!**

#### Step 8

Refit the stator baseplate. Ensure the wires **CANNOT TOUCH THE FLYWHEEL!** (especially on the inside of the flywheel)

#### Step 9

Refit the flywheel. Tighten the bolt to specified torque.

#### Step 10

Connect the wires to the wiring loom on the bike. Complete by fitting the ignition cover.

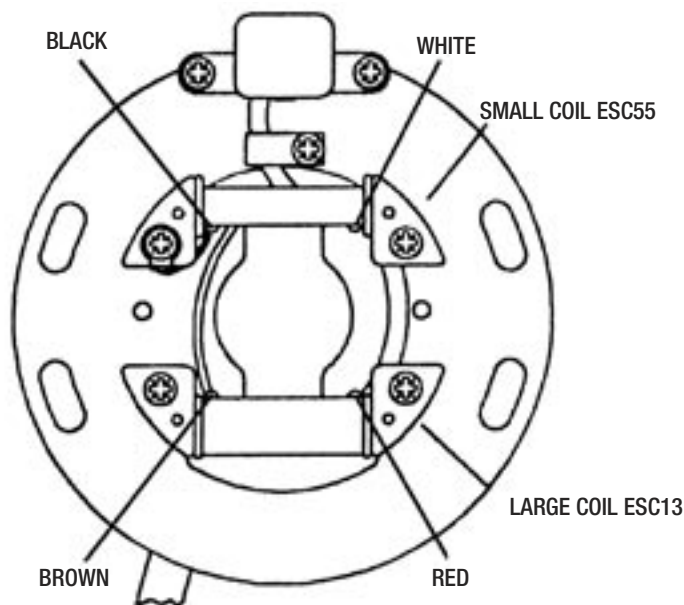
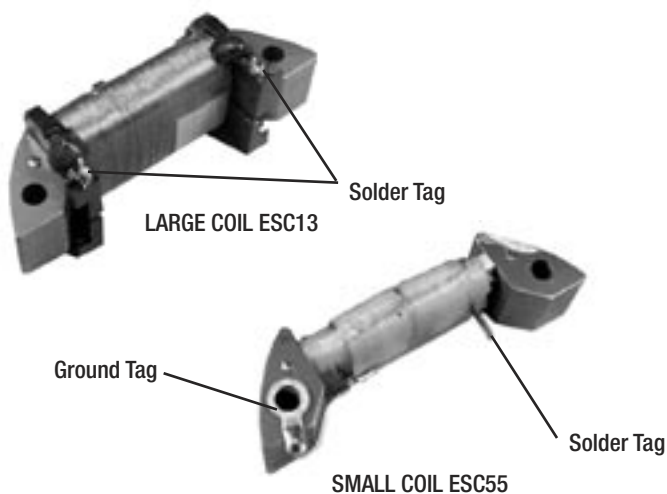

### Troubleshooting

**Engine will not start:** Sometimes the source coil wires are reversed. Swap the connections, resolder the wires and the engine should start. If the engine still does not start, and **before calling technical support at ElectroSport**, perform a few basic tests: 1) Re-check the connections. Make sure you carefully solder the connections. Twisting wires together or taping wires will cause engine inoperability. 2) Check the engine for spark and 3) Is fresh fuel in the gas tank? If you still cannot get the engine to start, have all your testing information ready for a technician prior to calling.