

# DAKAR

DUAL SPORT KITS



*RM250 DUAL SPORT KIT INSTALLATION INSTRUCTIONS*



## KIT CONTENTS

### Inspect Your Kit

Your kit will include the following items

#### A. RM250 Instructions and Wiring Diagrams

Read through the entire instruction manual before starting.

#### B. Dakar Headlight Assembly

#### C. Handlebar Turn Switch

#### D. Horn

#### E. Tail Light and Mounting Screws

#### F. Universal Hardware Bag (Contents)

-Turn Signals (2)

-Brake Light Switches (2)

-Cable Ties

-Wiring Diagram Label

-Round Plastic Signal Alignment Wedges

#### G. Main Wiring Harness

-Note: Ignition Keys Zip Tied to Harness

#### H. Mounting Kit Hardware Bag

-Triple Clamp Mounting Brackets

-Kit Specific Pieces

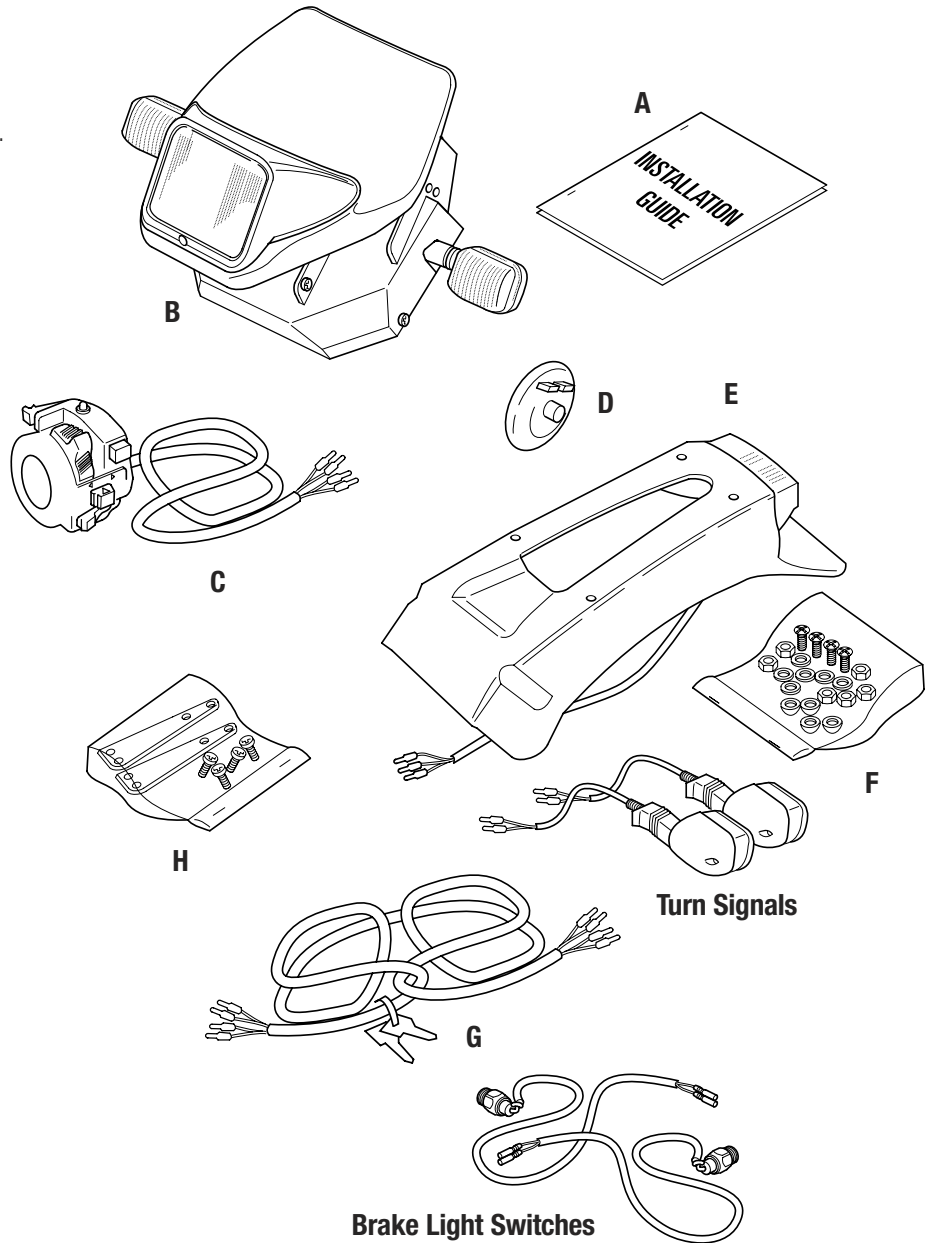

*Note: Please take a moment to become familiar with the contents of the kit. Due to slight variances between motorcycle models, there may be differences in the instruction manual drawings and the actual parts. The basic installation procedure remains the same.*

## HEADLIGHT UNIT SUB-ASSEMBLY

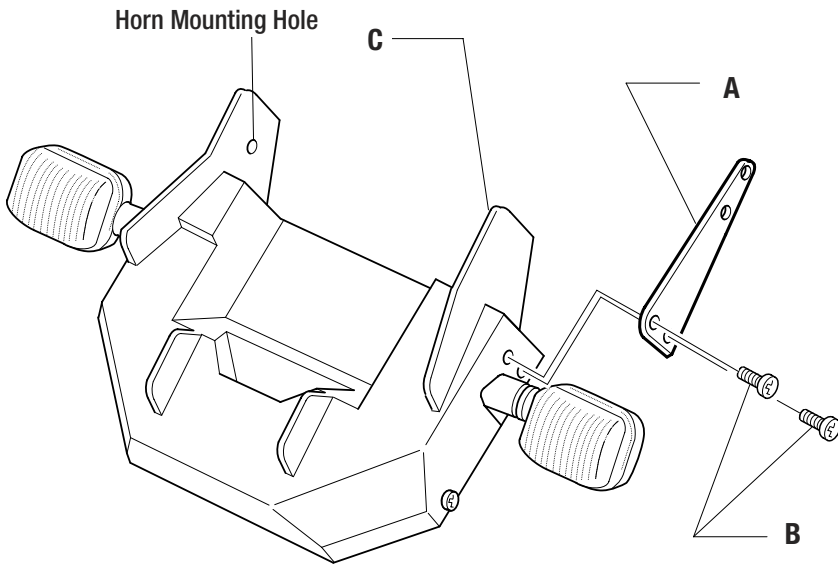

### Getting Started

Remove and retain four (4) retaining screws, holding the headlight numberplate to the Dakar unit. Then, unplug the main wiring harness, turn switch wiring harness, headlight and horn wiring connectors from the Dakar unit.

### Attach The Horn

The horn may already be installed on your kit, if not, the horn has a nut with a washer screwed on the back. Remove and retain the nut and washer. Locate the horn's threaded stud on the outside of the Dakar unit and into the horn mounting hole in the Dakar unit. Fasten with previously removed washer and nut. (Be sure to tighten securely without stripping)

### Mounting Brackets

Attach headlight mounting brackets (A) with two screws (B) on each side. Tighten screws securely into the Dakar headlight unit (C) without stripping.

Note: Bracket shown in illustration may differ from pieces in your kit. However, the installation will remain the same.

### Installing The Dakar Headlight Unit

#### Step 1

Remove and retain existing top triple clamp bolts (D). Carefully slide brackets into position and fasten with existing bolts as shown.

*WARNING: Torque triple clamp bolts as specified in your service manual.*

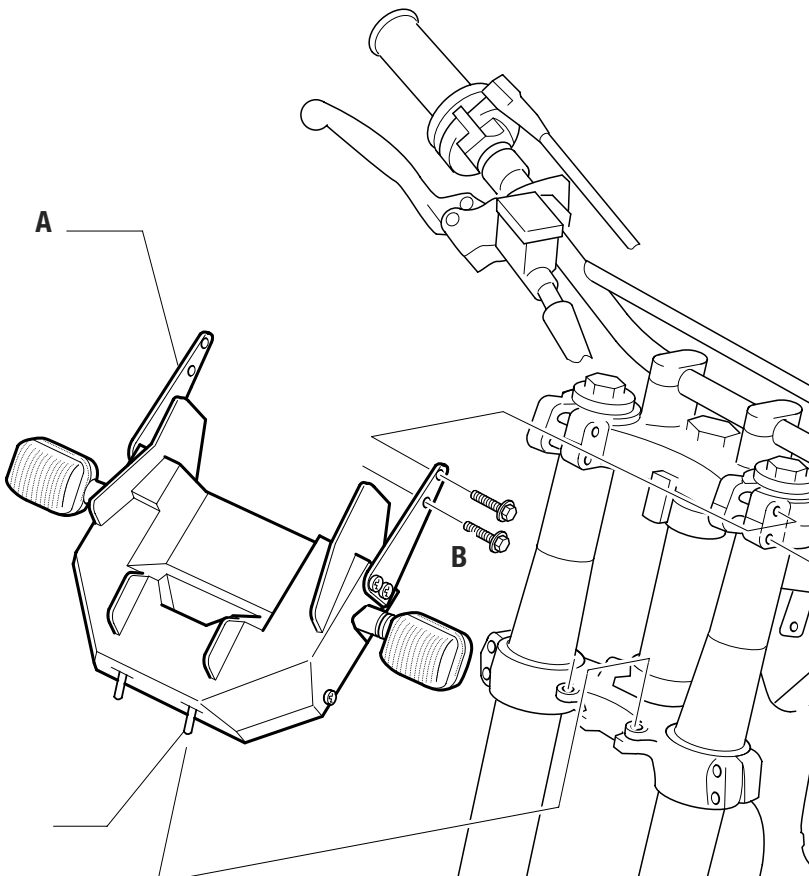

Note: Headlight assembly omitted for clarity.

## TURN SWITCH INSTALLATION

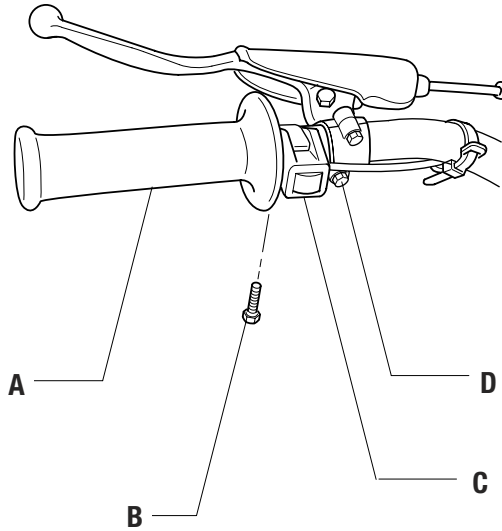

### Remove Existing Kill Switch

#### Step 1

Using a small phillips head screwdriver, loosen the locking screw ( B ) on the kill switch ( C ). Remove any cable ties and unplug kill switch from existing wiring.

#### Step 2

Loosen clutch cable perch ( D ) and move inboard about 1/2 inch.

### Install Turn Switch

#### Step 1

Open and wrap the new turn switch ( E ) around handlebar and securely fasten with two screws ( F ) as shown.

#### Step 2

Route turn switch wiring down and along handle bar behind Dakar headlight unit and in through frame cable guide. Secure switch wiring to handlebars with one cable tie. For more information, please refer to the cable routing diagram on page 2.

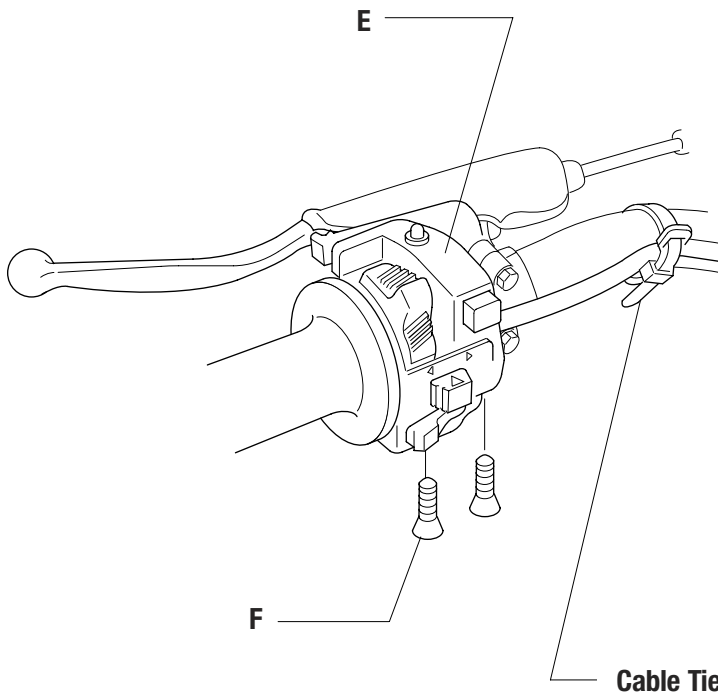

## BRAKE LIGHT SWITCHES

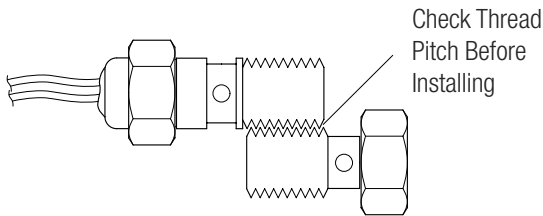

### **WARNING: Check the thread pitch on your banjo bolts**

Make sure the thread pitch on your stock banjo bolts match the replacement versions provided in the kit. More than likely they will match. Some manufactures have changed the stock design requirement which is why it necessary to check. If your parts do not match up, stop the installation and give us a call. We'll send replacement parts to you!

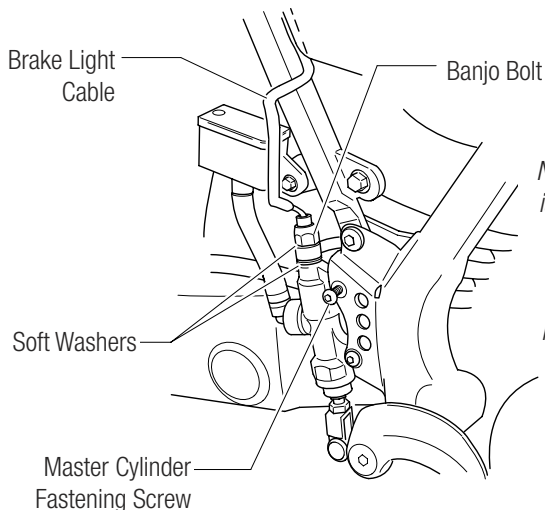
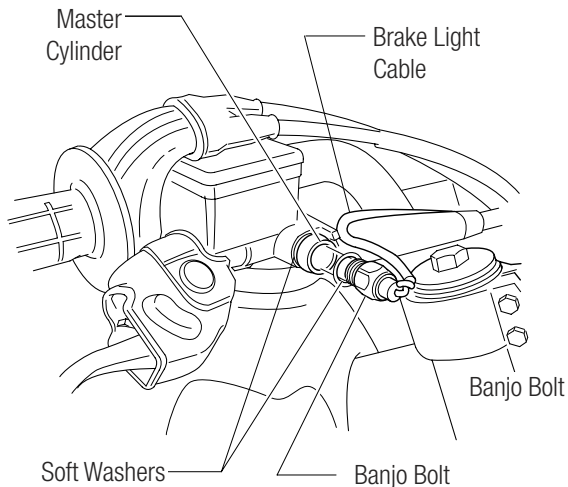

*Note: RM250 brake is visually different. However, the installation of the brake light switch remains the same.*

### Front Brake Light

#### **WARNING**

*Bleed front and rear brakes according to instructions provided in your owners or service manual. This must be performed in order for proper brake operation. Failure to do so may result in brake failure*

#### **Step 1**

Place a drop cloth or rag under the front brake and bike to catch any fluids. Loosen and retain banjo bolt on master cylinder.

#### **Step 2**

Insert brake light switch into position and fasten with banjo bolt on top of soft washer, hydraulic line and second soft washer. Securely fasten banjo bolt without stripping.

#### **Step 3**

Route the front brake light switch wiring along the lower portion of the handlebar towards the center of the triple clamps. Fasten wiring to the handlebar with a cable tie.

### Rear Brake Pedal Light

#### **Step 1**

Place a drop cloth or rag under the rear brake and bike to catch any brake fluid. Remove the screws and guard providing access to the rear brake master cylinder.

You must temporarily reinstall the screws that attach the master cylinder to the frame to prevent damage to the master cylinder or Banjo bolt threads. After the master cylinder is secure, carefully remove the existing banjo bolt. Remove and retain the mounting screws.

Note: Some bikes allow access to the master cylinder without removing a cover or guard.

#### **Step 2**

Insert brake light switch into position and fasten with banjo bolt on top of soft washer, hydraulic line and second soft washer. Securely fasten banjo bolt without stripping. Reinstall guard with screws

#### **Step 3**

Route the rear brake light switch wiring up the sub-frame spar and following behind the airbox up towards the back of the frame. The wiring should meet up next to the main wiring harness tail light and turn signal connection point.

**TAILLIGHT AND TURN SIGNALS**

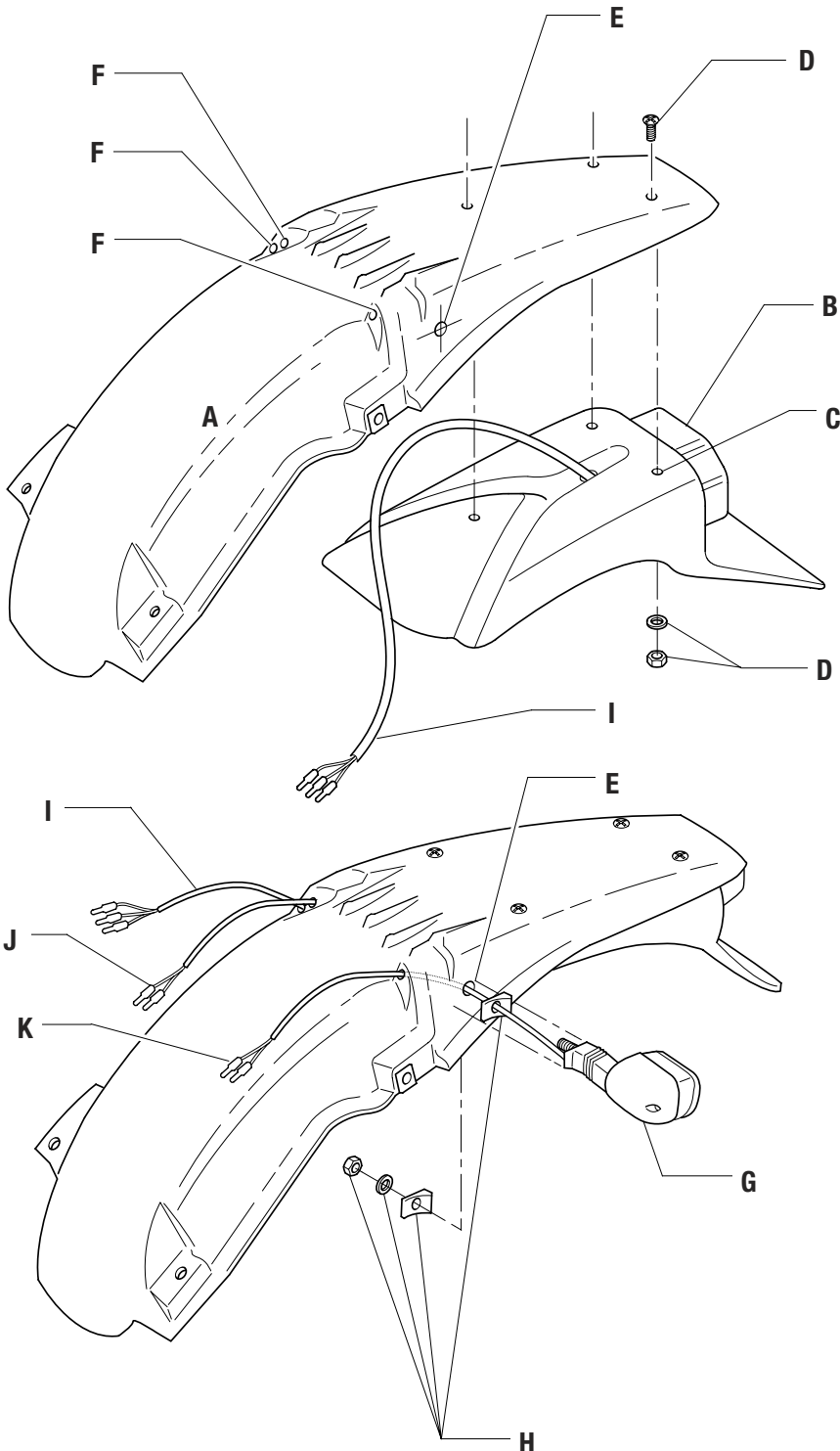

**Remove Existing Parts**

Remove your existing seat, front number plate, radiator covers, fuel tank, side number plates and rear fender. Please refer to your owners manual for detailed dis-assembly instructions for each item.

**Tail Light Assembly**

Place the rear fender (A) upside down on a clean work surface and position the rear tail light (B) on the inside of the fender. Note: the tail light should rest slightly under the rear edge of the fender.

Using the rear tail light's four mounting holes (C) as guides, trace around each hole with a felt tip marker on the underside of the fender creating drill hole locations. Remove the tail light and drill 1/4 inch holes. Reposition the tail light, and fasten with supplied screws, washers and nuts (D) as shown.

**Turn Signal Mounting**

**Step 1**

Position the rear turn signals by visually lining up the signals (G) behind the rear seat, when its attached to the sub-frame. Care should be observed to insure signals do not interfere with the rear silencer. The signals must mount free and clear of exhaust heat in order to prevent damage to the signal.

Once you have found a suitable location for the signal mounting hole (E), mark and drill one 3/8 inch hole through each side.

**Step 2**

Drill a second hole (F) on each fender side, allowing the signal wiring to pass through underneath the rear seat. Note: On some bikes, signal wiring holes are already available.

**Step 3**

Feed the tail light wiring (I) through the right side hole and then the turn signal wiring (J). Secure turn signal with supplied alignment wedges, washer and nut (H). Attach second turn signal following same procedure and complete by reinstalling rear fender on bike.

*Note: There may be differences in the instruction manual drawings and the actual parts.*

**TAILLIGHT AND TURN SIGNAL CONNECTION**

**Cable Routing Harness Location**

Feed the main wiring harness through the frame cable loop behind the triple clamps. For more information, please refer to cable routing diagram. For reference, stick the wiring connection decal on the rear fender, below where the seat will cover it up.

**Taillight Connection**

Connect the WHITE tail light male to the GRAY female connector. Connect the BROWN tail light male ground to the BLACK female connector as shown.

**Turn Signal Connections**

Connect both BLACK tail turn signal grounds into the dual BLACK female ground connector. Connect the ORANGE female into the BLACK male (right turn signal) connector, and the PINK female, into the BLACK male, (left turn signal) connector.

**Brake Switch Connection**

Connect one of the BLACK brake switch male into the BROWN female connector and the second BLACK brake switch male into the dual VIOLET connector.

**Note**

Be sure to carefully and fully seat the connectors into position.

**Secure Cable Ties**

Use a few cable ties along the sub frame to hold the harness into position. Make sure that you secure the harness to frame areas that will not bind or crimp the harness.

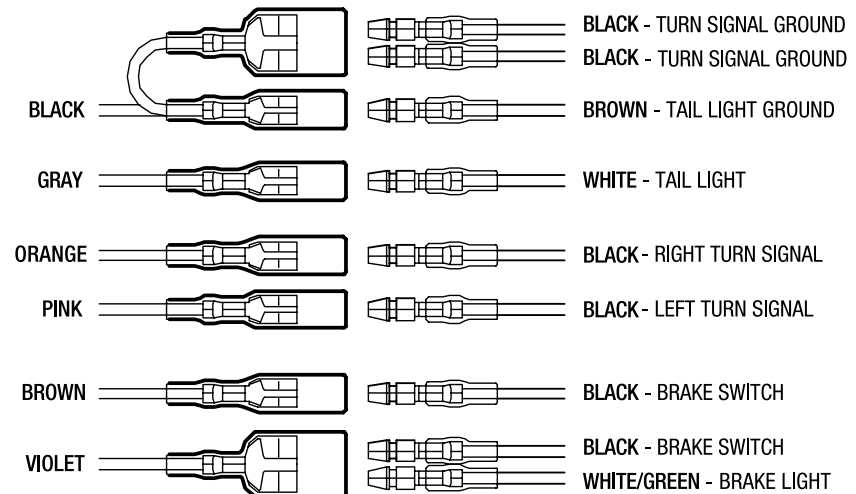
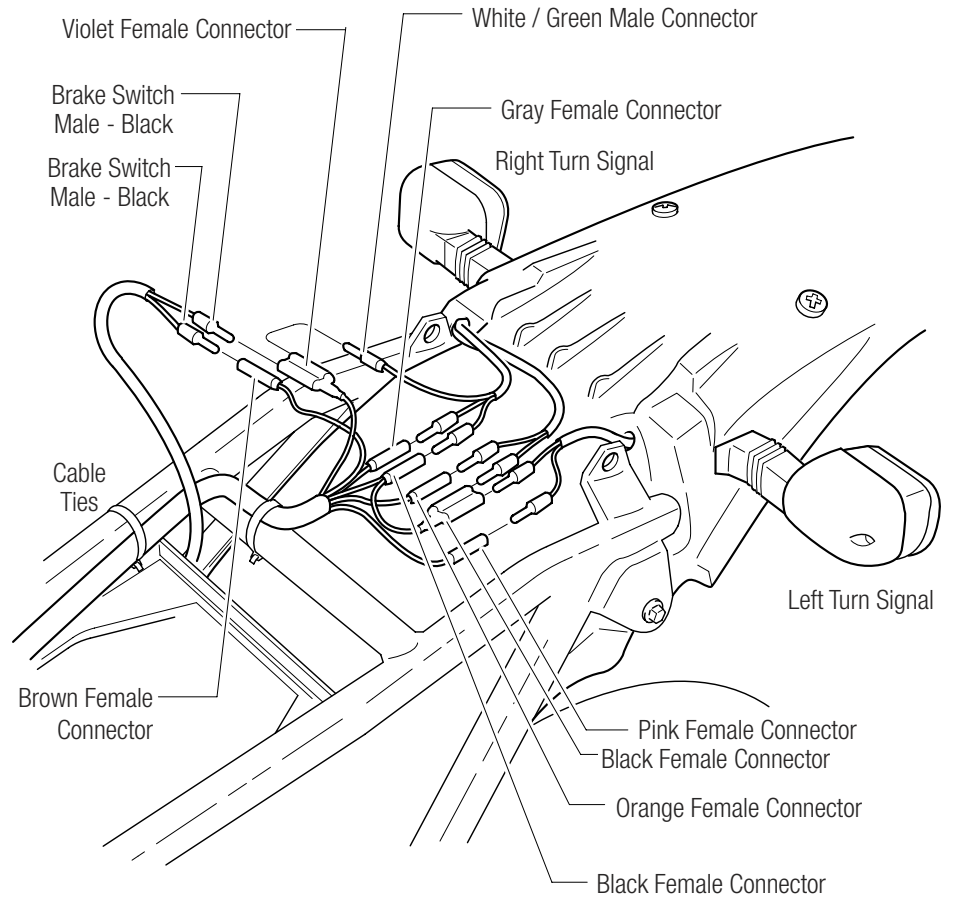



## HEADLIGHT WIRING

### Main Wiring Harness Connection

Access the Dakar wiring located behind the headlight, by loosening two lower screws and remove two top inboard screws. This is required in order to provide enough freeplay to tilt the headlight forward for harness connections. Please refer to headlight adjustment for more information.

From the main wiring harness, connect the VIOLET and BROWN female connectors into the front brake light switch male connectors.

Plug-in main wiring harness (right side) connector. Be sure to fully seat the connection. You will hear the connector "click" into position on both the top and bottom.

### Horn Connection

From the turn switch wiring harness, connect the PINK and BLUE leads, into the horn spade connectors.

### Turn Switch Wiring Connection

Plug-in main turn switch wiring harness connector into the right side block connector on the Dakar unit. Be sure to fully seat the connection. You will hear the connector click into position on both the top and bottom.

### Main Wiring Harness Connection

Plug-in main Main wiring harness connector into the left side block connector on the Dakar unit. Be sure to fully seat the connection. You will hear the connector click into position on both the top and bottom.

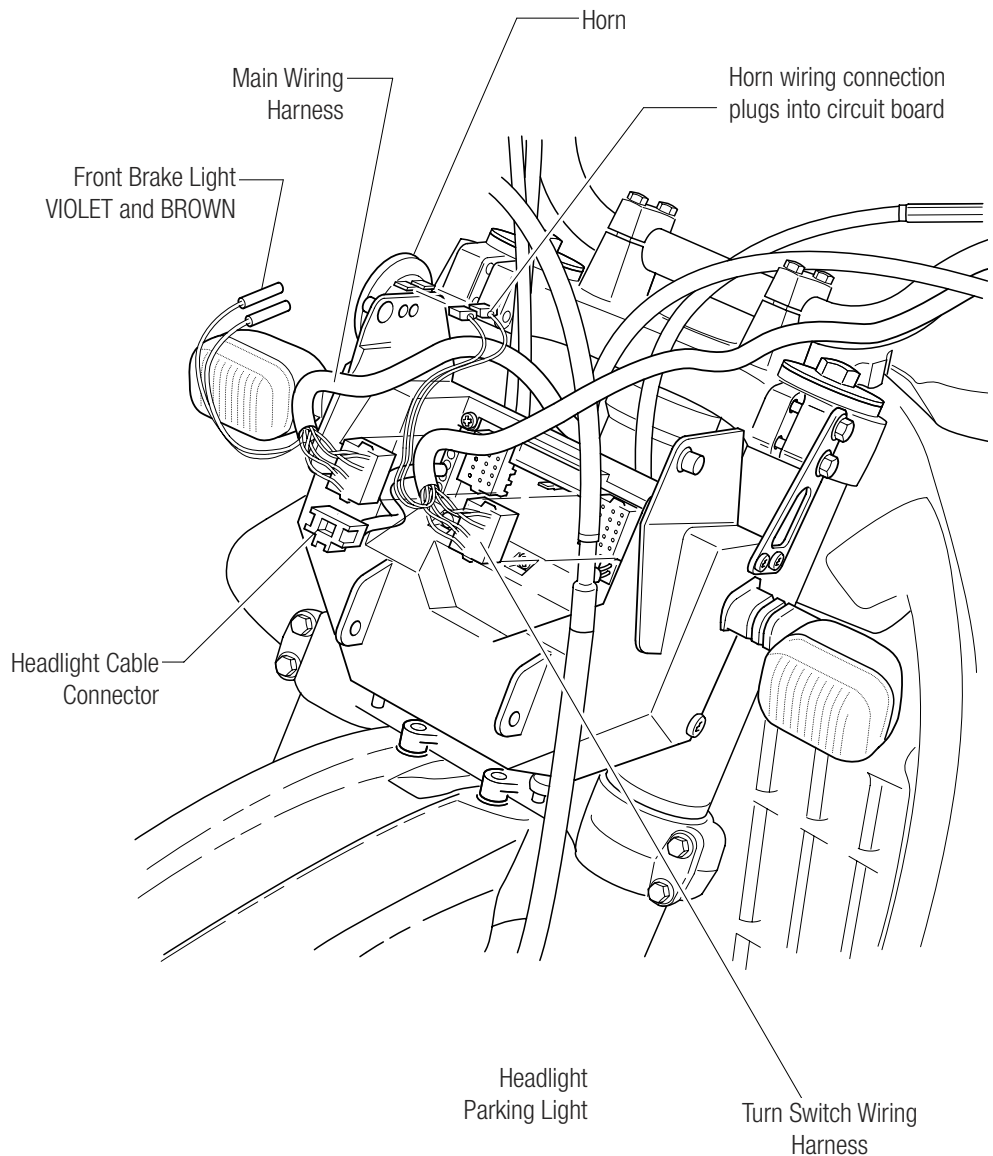



## HIGH OUTPUT STATOR REQUIREMENT

### Power Requirements

The RM250 must have an E-Line style high output stator installed in order for the stator to output enough power to operate a Dual Sport Kit.

The requirement of using this set-up is specified on our website and product guides as a requirement for converting the CR500 to use with a Dakar Dual Sport Kit. If you have not ordered this part, stop the installation and order the E-LINE part.

This product can be ordered direct from E-Line or other distributors. E-Lines phone number is 508-295-0812. E-LINE can be found on the internet at [www.elineaccessories.com](http://www.elineaccessories.com)

For specific installation notes please refer to the E-LINE installation documentation that comes with this product. This set-up works excellent and we have installed many of these on the RM250. Its really the best option for the Dakar dual sport kit and we highly recommend it.



Included with the E-LINE product is an entire sidecase and external generator coil. The wiring connection is a direct plug-in into the Dakar Dual Sport Kit.

The E-LINE kit includes a flywheel adapter which provides additional power output for the charging system in the Dakar kit

The E-LINE kit includes a simple regulator rectifier. **It is not used.** The Dakar kit has a built in regulator rectifier.

**STATOR WIRING HARNESS CONNECTION**

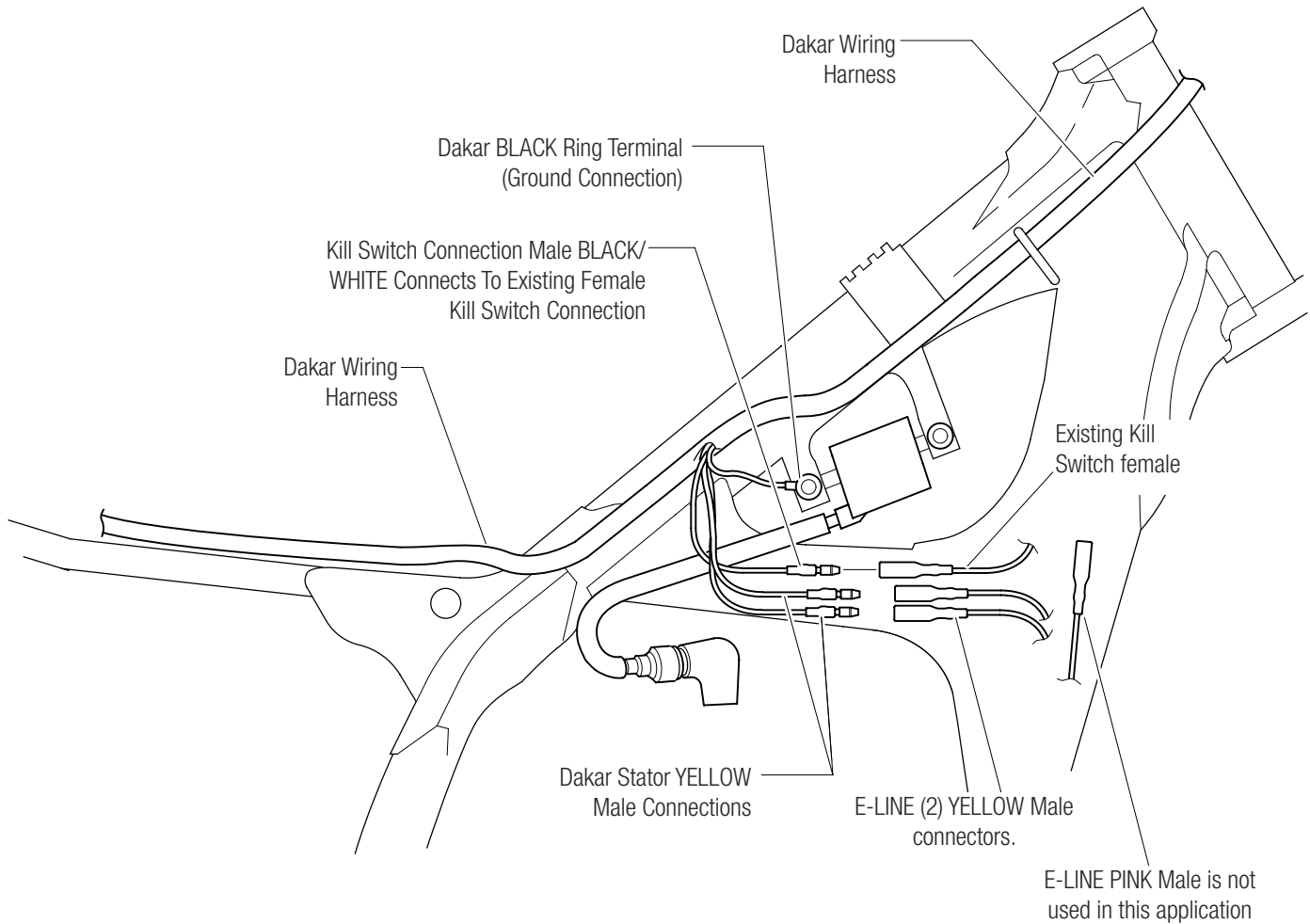

**Dakar Wiring Harness Ground Connection**

Connect the main wiring harness BLACK ground ring terminal to the existing ignition coil ground location.

**Dakar Wiring Kill Switch Connection**

Connect the Dakar wiring harness BLACK/WHITE male kill switch wire to the existing kill switch female connector.

*NOTE: Your motorcycle CDI kill switch should be a black and white wire. If not, please refer to your owners manual.*

**Stator Connection**

Connect both female YELLOW connectors from the E-LINE wiring harness into the two YELLOW Dakar male connectors.

Note: The E-LINE stator wiring also has one female PINK connector which is not used in the Dakar application. Do not connect this, just tie it off to the wiring harness with a few cable ties.

## HEADLIGHT BEAM ANGLE ADJUSTMENT

### Attaching The Headlight

After the wiring harness has been securely fastened and the complete system has been tested, you can now tilt the top of the headlight into the riding position and fasten the two inboard screws (A) as shown. Complete the assembly by tightening the lower two screws (B).

### Accessing the wiring behind the headlight

When accessing the Dakar wiring located behind the headlight, you must loosen the two lower screws (B) and remove the two top screws (A). This is required in order to provide enough clearance while tilting the headlight forward.

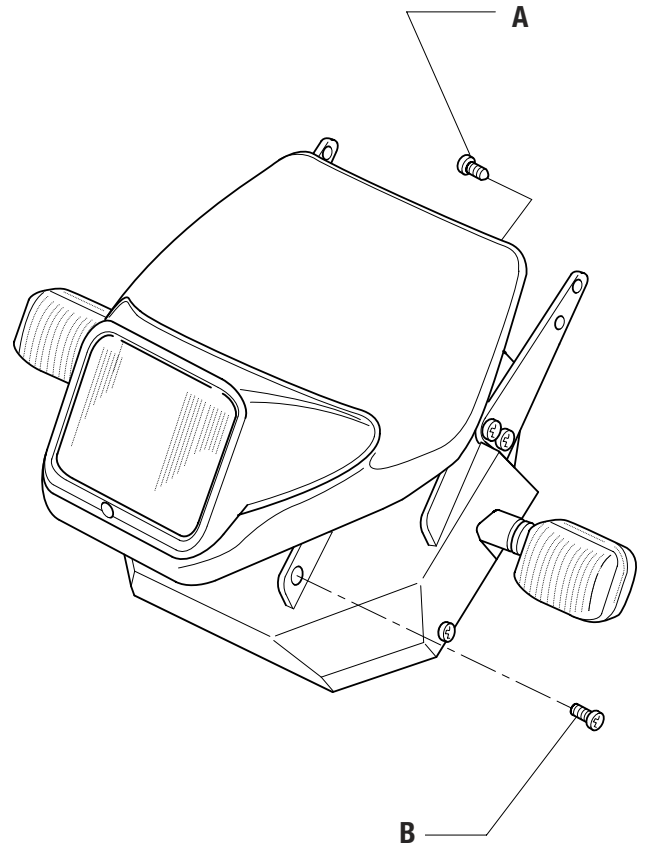

## BEFORE RIDING YOUR BIKE

### Ignition Key

The Dakar Dual Sport Kit features a security key designed for theft prevention and unauthorized operation of the motorcycle. To start the motorcycle, rotate the key to the ON position as shown.

*IMPORTANT: Do not leave the headlight on without the engine running. It could cause damage to the battery. We also suggest turning up the idle speed slightly to increase system voltage while the engine is at idle.*

The key is designed only as a means to disable operation of the motorcycle. Use the turn signal kill switch to shut the motorcycle off. Leaving the key in the ON position will drain the battery, so be sure to turn the switch to the OFF position while leaving the bike unattended. Now start your bike up and go show your friends!

**Key OFF Position**

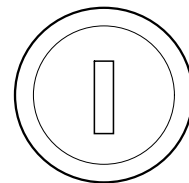

**Key ON Position**

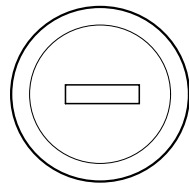



## **Overview**

Vehicle registration policies in most states typically allow conversion of an off-road only title into a street title or in some states a designated "Dual Registration." To register a dirt bike for street use, it must be equipped with the necessary lighting and other equipment required by your state's vehicle code.

### **Every state requires what is called "The Federal Minimum Requirement" which consists of:**

- Headlight with a high and low beam
- Headlight indicator light visible to the operator to show when the high beam is operating
- Horn - Some states mandate an electric horn
- Battery powered taillight and brake light which must operate for 20 minutes on battery power alone
- Rear view mirror
- Turn signals for motorcycles manufactured after 1/1/73 (Most States)
- Some states require speedometers and odometer's
- Tires should be DOT approved
- Lights should be DOT approved
- Fuel tank should be DOT approved\*

\* *Even though the Federal Motor Vehicle Safety Standard specifies steel gas tanks for street motorcycles, most states will not enforce this for converted dirt bikes*

### **Registration procedures vary from state to state but typically involve:**

- Signing two "Statement of facts" certifying that your bike meets state/federal standards.
- Bringing the bike to the DMV or (AAA Insurance Office) for an inspection for proper lighting
- Once the paper work and inspection are complete the final step is to exchange your off-road title for a street title

### **Exchanging your title**

Most states have a "Dual Registration Form" You should be able to download this form from your states DMV over the internet or filling it out at your DMV office. Then pay the transfer fee and obtain your registration, put the plate on your bike and go show your friends!

## **Nothing Happens When You Turn the Power Switch On**

### Possible Causes

- Fuse is blown. Check for bare wire or terminal shorting against the frame or another wire.
- Multi-pin connector not properly connected to the circuit board.
- Poor battery connection. Make sure the connectors are fully seated.
- Battery is flat. Measure voltage with voltmeter, or connect a 12 volt light across it. A fully charged battery will measure between 12.9 and 13.2 volts.
- Poor connection at the blue wire junction above the shock.

## **Headlight does not work on high beam or low beam:**

### Possible Causes

- Check the bulb. Usually one of the bulb filaments is bad, so replacing it will fix the problem. Make sure you replace the bulb with the exact same wattage.
- The handlebar switch is dirty inside. Clean it out with some WD40.

## **Headlight is dim at idle:**

### Possible Causes

- Increase the idle speed a little. Dual sport setups work a lot better if the idle speed is a bit "on the high side". This is due to the design of most of the lighting /charging coils, which really start putting out power at around 1200 rpm.
- Battery is not charged. Charge battery using a standard battery charger. Connect the black (negative) lead from the charger to a good frame ground, and connect the red (positive) lead from the charger to the blue lead that connects to the horn. (just slide the blue connector sleeve back, and connect the charger up to the exposed terminal) You do not need to disconnect the horn. Turn key switch to "ON" Position.
- Check bulb wattage. Certain kits come with a lower wattage bulb than a standard H4 bulb. ElectroSport has all bulbs in stock.

## **Taillight does not work:**

### Possible Causes

- Check the bulb. Due to vibration the bulb could have gone out. Check the connections in the bulb holder as well, water could oxidize the contacts, preventing the bulb from coming on.
- Check the connections, especially the ground under the seat. You'll find a gray wire (taillight positive), a black wire (taillight and brakelight ground) and a violet wire (=purple, brake light positive). Check these connections carefully.

### **Brake light stays on:**

#### Possible Causes

- unplug the brake light switches one by one. If one of the switches is bad, it will close its contacts and leave the brake light on. The brake light switch that makes the brake light turn off as soon as you unplug it, is bad.

### **Brake light does not work:**

#### Possible Causes

- Check the bulb. Due to vibration the bulb could have gone out. Check the connections in the bulb holder as well, water could oxidize the contacts, preventing the bulb from coming on.
- Check the connections, especially the ground under the seat. You'll find a gray wire (taillight positive), a black wire (taillight and brakelight ground) and a violet wire (=purple, brake light positive). Check these connections carefully.

### **Blinkers don't work:**

#### Possible Causes

- Battery is not charged. Charge battery using a standard battery charger. Connect the black (negative) lead from the charger to a good frame ground, and connect the red (positive) lead from the charger to the blue lead that connects to the horn. (just slide the blue connector sleeve back, and connect the charger up to the exposed terminal) You do not need to disconnect the horn. Turn key switch to "ON" Position.
- flasher relay is bad. Replace with new one.

### **Blinkers don't work at idle, or flash intermittently:**

#### Possible Causes

- Battery is not charged. Charge battery using a standard battery charger. Connect the black (negative) lead from the charger to a good frame ground, and connect the red (positive) lead from the charger to the blue lead that connects to the horn. (just slide the blue connector sleeve back, and connect the charger up to the exposed terminal) You do not need to disconnect the horn. Turn key switch to "ON" Position.
- increase the idle speed a little. Dual sport setups work a lot better is the idle speed is a bit "on the high side". This is due to the design of most of the lighting /charging coils, which really start putting out power at around 1200 rpm.

### **Horn doesn't work:**



Possible Causes

- Battery is not charged. Charge battery using a standard battery charger. Connect the black (negative) lead from the charger to a good frame ground, and connect the red (positive) lead from the charger to the blue lead that connects to the horn. (just slide the blue connector sleeve back, and connect the charger up to the exposed terminal) You do not need to disconnect the horn. Turn key switch to "ON" Position.
- Adjust small set screw on the back side of the horn. Turn it both ways until you get a nice loud "honk"

**Lost key while riding:**

Possible Causes

- The Dakar setup will perform fine, but you'll have to top up the battery regularly (weekly) to prevent it from going flat. Call ElectroSport for a replacement.

**Kill button does not work:**

Possible Causes

- Ensure that the black/white wire of the wiring harness is plugged in correctly.
- If the kill button does not work, but turning the key switch does kill the engine, you have a dirty handlebar switch. Spray inside it with WD40.

**Technical Support Contact Information**

ElectroSport Industries  
3803 Oceanic Dr. Ste 201  
Oceanside CA 92056  
PH: 760-842-8300 (9-5 M-F PST)  
WEB: [www.electrosport.com](http://www.electrosport.com)  
email: [Info@electrosport.com](mailto:Info@electrosport.com)